

 **legris**



**Legris,
A leading partner
in the automotive process
industry**



**High quality standards,
Innovative solutions,
Worldwide availability.**



**Extensive ranges of technical
components and evolutionary
services which set a benchmark
within this demanding market.**

For over 40 years, Legris has worked as a partner within automotive process industries, including vehicle constructors, OEM production 1st tier suppliers, tier suppliers and robotic integrators.

Successive teams have developed industry specific experience and technical expertise, resulting today in an extensive range of technical components, special products and services. The Legris offer combines high **quality**, **innovation** and **worldwide availability**, backed up by Legris' local presence throughout the world.

This brochure features many of the solutions provided by Legris – whether standard or special, whatever the application, in order to contribute to its customers' **performance**.



Vehicle builders across Europe, America and Asia who choose Legris

Car manufacturers, OEM, 1st tier suppliers and robotic integrators

ABB MC

DAIMLER CHRYSLER (POWERTRAIN)

DÜRR

FAURECIA

HONDA

MICHELIN

PSA PEUGEOT CITROËN

RENAULT

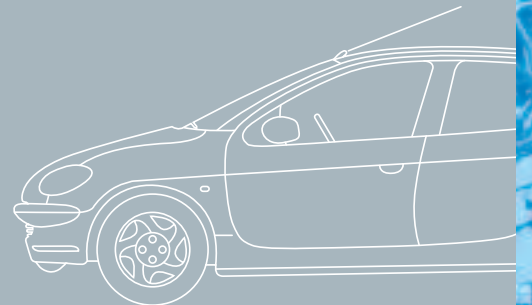

Designed and manufactured in order to protect the **environment** and to safeguard public health, Legris products comply with the **ELV 2000/53/CE** directive for the reduction of hazardous substances in cars.

The Legris offer meets all main requirements

Legris is involved in many stages of the manufacture of motor vehicles. From the **distribution of fluids** in workshops, with **Transair** pipe networks, to **production lines** and **assembly machines**, and **Connectic** product ranges - for pneumatic, industrial fluids and hydraulic applications - the Legris offer meets all main requirements.

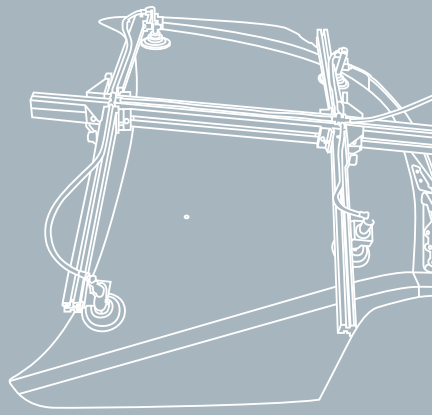

PRESS SHOP
Secure connections that withstand vibration

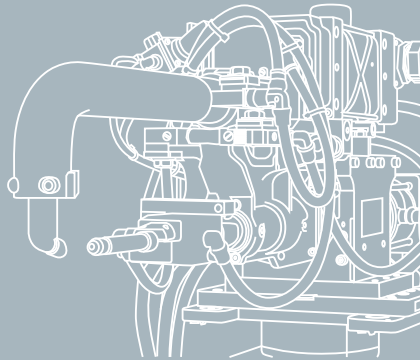

BODY SHOP
Excellent resistance to aggressive weld spatter

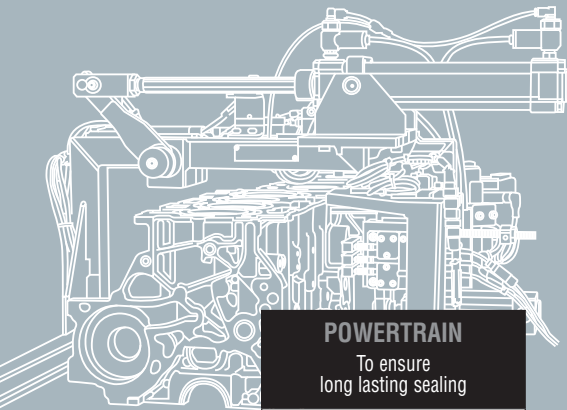
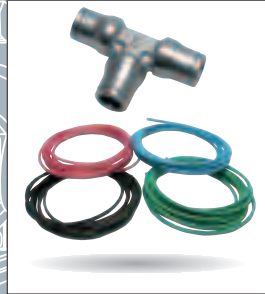

POWERTRAIN
To ensure long lasting sealing

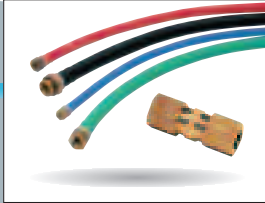

PAINT SHOP
To ensure top quality paint finish

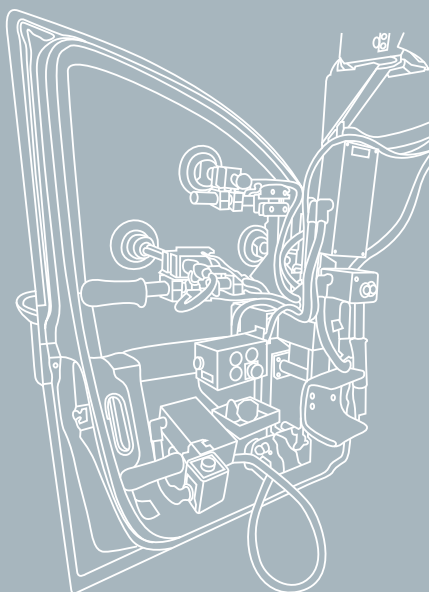
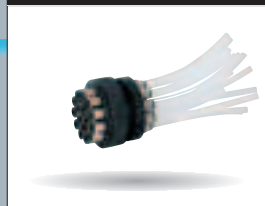

ASSEMBLY SHOP
To contribute to work station safety



CONTROL
To adapt to any fluid circuit configurations



Press shop

Secure connections that withstand vibration

During the first stage of vehicle manufacture, steel plate is pressed into shaped parts that will form the car body. **Stamping presses** incorporate automatic parts handling equipment and heavy duty **pneumatic automation**.



■ STAMPING PRESSES

Equipment productivity and clean installations require completely reliable connections for use in environments that are submitted to intense vibration.



THE LEGRIS ANSWER DiNova sealing ring for DIN 2353 / ISO 8434-1 couplings.

- Excellent resistance to vibrations, thanks to an increased area of connection with the tube upon tightening.
- Long lasting sealing, ensured by 3 bites and 2 seals.
- Easy installation thanks to a low tightening torque.

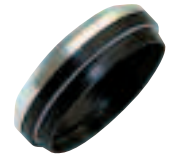

Components suited to the requirements of **press shop machinery.**

■ PANEL HANDLING EQUIPMENT

Installed on robots, grippers enable panel transfers in pressing and forming work stations. Much of this activity relies on **vacuum**.

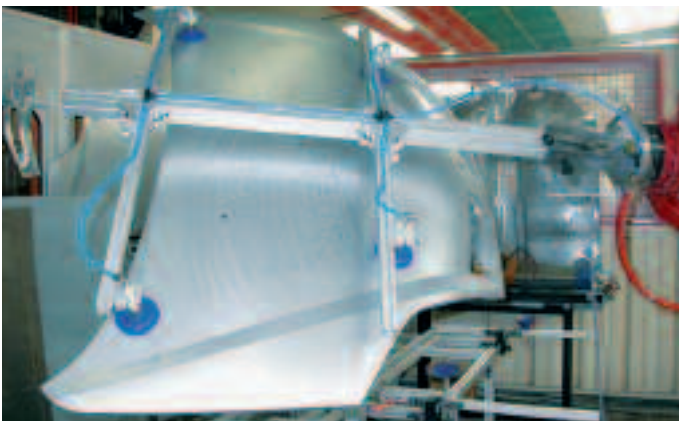

THE LEGRIS ANSWER instant fittings in **HR polymer**, **chemical nickel-plated brass** and **close tolerance** **polyurethane tubing.**

- High vacuum capability.
- Resistance to repetitive movements, with close tolerance flexible polyurethane tubing.
- Installation and maintenance time saving, thanks to instant connection/disconnection.



Components suited to the requirements of **gripper manufacturers.**

Body shop

Excellent resistance to aggressive weld spatter

Spot welding – strip steel plate fabrication incorporates resistance welding processes to form the car body. Such equipment is submitted to particularly severe conditions (heat, weld spatter, cryogenic washing down).

■ SUPPLY TO WELDING U-CELLS

U-cells require fluid supply pipe drops (particularly for compressed air, cooling liquids and vacuum) to be positioned very close to work stations.



■ SECURE CONTROL OF FLUIDS

Active visual control enables the opening and closing of circuits in order to prevent all potentially dangerous consequences that can be caused by unintended operation, thus ensuring the safety of workers and equipment.

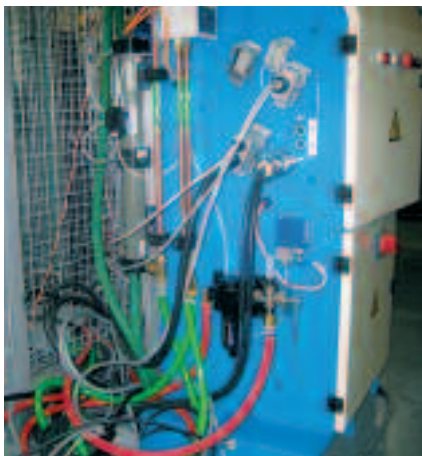

THE LEGRIS ANSWER
Transair pipe networks for compressed air, vacuum, inert gases and cooling water.

- Perfectly suited for most equipment.
- Assembly under pressure allows maintenance operations without production line shutdown.
- Cost saving, thanks to easy, instant assembly and high flow performance.
- TÜV certified.



Components suited to the requirements of **welding integrators.**

THE LEGRIS ANSWER
Multi-directional and **lockable ball valves.**

- Lockable in different positions.
- Compatibility with numerous fluids.
- Various configurations.



Components suited to the requirements of **welding integrators.**

■ ROBOTS AND PRE-EQUIPMENT OF ROBOTS

For optimum performance of robotic equipment, fluid supplies (compressed air and cooling water) require reliable connection technology that is resistant to spatter.

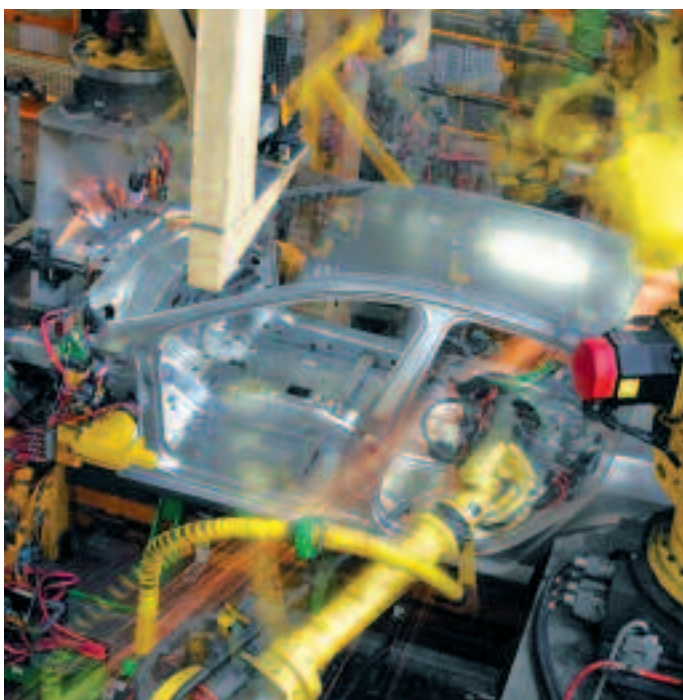

THE LEGRIS ANSWER compression fittings, flow control regulators and barbed connectors in brass with self fastening hose.

- Reliable connection technology.
- Resistance to welding environments.
- Compatibility with numerous fluids.

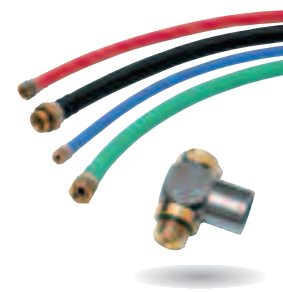

Components suited to the requirements of robotic equipment integrators.

THE LEGRIS ANSWER swivel instant fittings.

- Full safe connection between the welding tool and the robot arm.
- Follow robotic movements.
- Instant connection/disconnection, without tools.



Specifically designed and developed for this type of dynamic application.

■ WELDING PLIERS, GRIPPERS AND PALLET-CONTAINERS

Such equipment, as used in the preparation and manipulation of parts, requires spatter resistant connections for compressed air circuits.

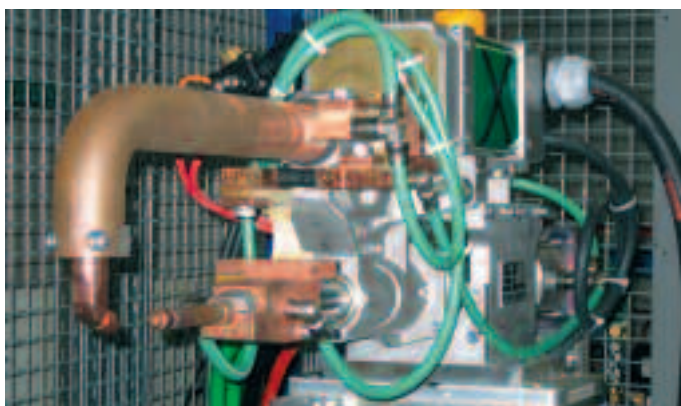

THE LEGRIS ANSWER push-in fittings in chemical nickel-plated brass and anti-spark tubing.

- Chemical nickel-plated brass provides full protection against aggressive environments.
- Optimum combination with Legris anti-spark tubing, designed to prevent against fire and combustion (conforming to **UL94 V0** standard).
- Instant manual connection and disconnection, resulting in time-saving installation and maintenance.



Components suited to the requirements of specialist equipment.

Paint shop

To ensure top quality paint finish

After preparation, each car body is transferred to the paint shop. It is essential that connectors and pneumatic components preserve the quality of the paint finish.

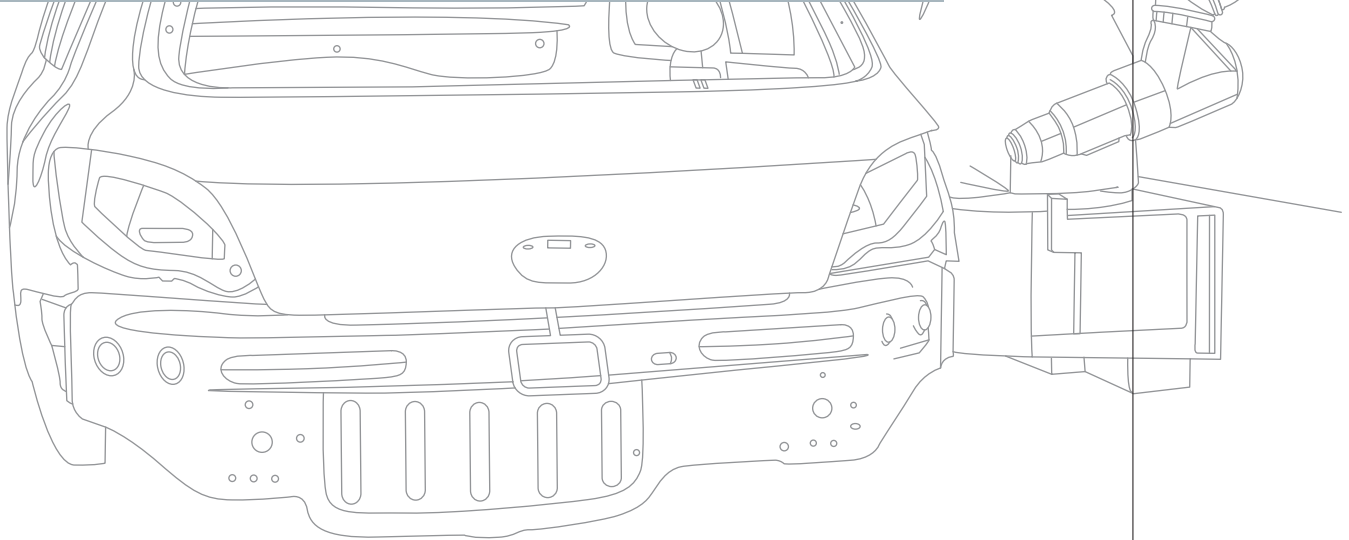

■ PAINT DISTRIBUTION

Automatic, or manual, distribution of paint during vehicle assembly requires a range of components that can ensure the prevention of damage to painted surfaces.



THE LEGRIS ANSWER special push-in fittings in HR polymer.

- **Specifically** designed and produced for "painting" applications.
- **Special** non spoil grease preserving the adhesion of paint.
- Instant manual connection and disconnection, resulting in time-saving.
- Many configurations suitable for all circuits.
- Optimum performance with FEP tubing, resistant to aggressive and corrosive conditions.



Components designed and developed in close collaboration with **paint equipment manufacturers.**



Multi-connector, designed and developed jointly with **paint equipment manufacturers.**

You will find on legris.com other ranges that are perfectly suited for use on painting equipment.

- push-in fittings in **stainless steel**
- function fittings in **stainless steel**:
flow regulators, non-return valves and quick exhaust valves.

Assembly shop

To contribute to work station safety

At the final assembly stage, the painted car body is successively equipped with all remaining parts of the vehicle: trims, upholstery, electric circuits, windows and power systems. The filling of various fluid circuits on each vehicle (oils, fuels, Freon...) completes the main activity. As well as securing individual components, the connectors that are used on tools must contribute to **workshop safety**.

MANUAL LINES

On such installations, **pneumatic tools** require frequent connection and disconnection (e.g. screwdrivers). Repetitive, fast and safety foolproof operations require the use of quick acting couplers designed to ensure reliable performance and guaranteed user safety.



THE LEGRIS ANSWER quick acting safety couplers in polymer and metal.

- Operator safety is guaranteed by an integral foolproof controlled air release system. Coupling and probe cannot be forced apart which, with a short vent-time, prevents whip-lash.
- Comply with **ISO 4414** and **EN 983** safety standards.
- **Energy efficient**, due to extremely low pressure drop.
- Very high **flow**.
- Optimum combination with various tubing (nylon and recoil polyurethane, PVC and rubber).



Components suitable for the requirements of **assembly line manufacturers**.

AUTOMATED LIQUID FILLING LINES

Liquid filling line work stations require safe circuitry and need to be compatible with numerous fluids.



THE LEGRIS ANSWER piloted axial valves enabling automatic opening and closing.

- Numerous compatible fluids.
- Extremely compact with a fast open/close time compared to actuated ball valves.
- Very high flow.



Components suitable for the requirements of **automated assembly line manufacturers**.



Priming tool designed and developed in close collaboration with our customers.

You will find on legris.com other ranges perfectly suited to the requirements of **manual and automated assembly line manufacturers**.

- push-in fittings in HR polymer
- close tolerance flexible polyurethane tubing.

Powertrain

To ensure long lasting sealing

Powertrain comprises two stages: machining and assembly of mechanical power devices for the vehicle. Equipment used for the **machining** of mechanical parts is submitted to an aggressive environment and the use of corrosive fluids.

■ TRANSFER LINES AND MACHINING

For each application, fittings need to be reliable and compatible with a variety of fluids.



THE LEGRIS ANSWER
DIN 2353 / ISO 8434-1
couplings fitted
with a **DiNova** ring.

- Long lasting performance, ensured by 3 bites and 2 seals.
- Withstand aggressive fluids and high temperatures, thanks to the seal material (PTFE).
- Safe connection, even in extreme conditions of use.



Components suited to the requirements of **machine tools** and **mechanical production line manufacturers**.

■ VEHICLE CLEANSING/WASHING MACHINERY

Such equipment operates with aggressive fluids and thus requires robust and high performance fittings.

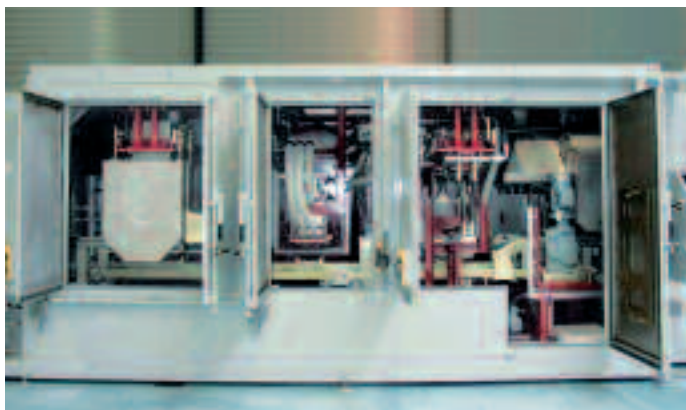

THE LEGRIS ANSWER
brass compression fittings,
quick barbed fittings
and **self fastening hose.**

- Compatibility with numerous fluids.
- Excellent resistance to abrasion.
- Reliable self fastening technology.

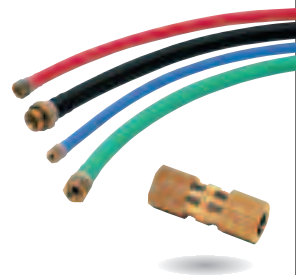

Components suitable to the requirements of **machine tools** and **mechanical line manufacturers**.

Powertrain

To meet requirements for durable performance

At the **assembly** stage, the mechanical power devices of the vehicle (motors, transmission, universal joints) are assembled with automatic or manual pneumatic tools, requiring high **performance** and safe connection.

MANUAL AND AUTOMATIC ASSEMBLY LINES

Pneumatic tools used for the assembly of mechanical devices are subject to frequent connection and disconnection.

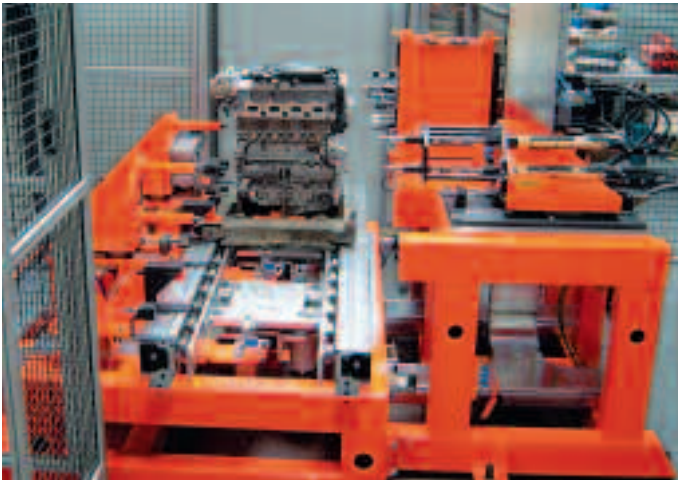

THE LEGRIS ANSWER push-in fittings in chemical nickel-plated brass.

- Full flow durable performance, without pressure drop.
- Easy assembly, thanks to instant connection/disconnection.
- Excellent resistance to abrasion and corrosion.



Components adapted to the requirements of **safety** and **assembly line manufacture**.

THE LEGRIS ANSWER quick acting safety couplers in HR polymer and metal.

- Designed for installations which require frequent instant connection and disconnection.
- **Energy efficient**, with extremely low pressure drop.
- Comply with **ISO 4414** and **EN 983** safety standards.
- Very high flow.



Components adapted to the requirements of **safety** and **assembly line manufacture**.

CONVEYORS

During the whole assembly operation, parts are conveyed from one work station to another by conveyor systems equipped with pneumatic components.

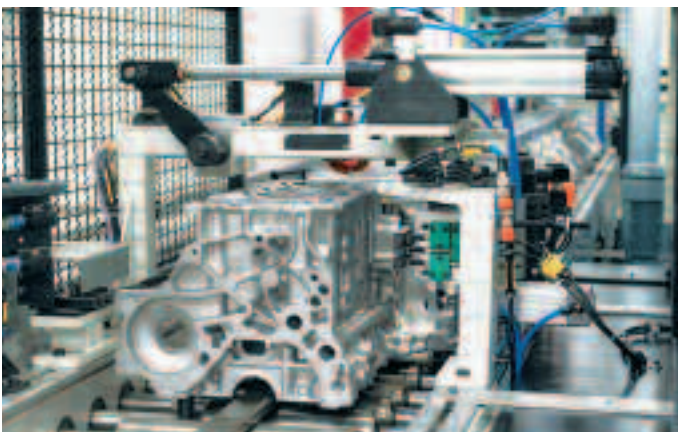

THE LEGRIS ANSWER push-in fittings and flow regulators in HR polymer, silencers.

- High flow, high pressure performance, full passage of fluid without pressure drop.
- Easy assembly, thanks to instant connection/disconnection.



Components adapted to the requirements of **handling systems** and **production line manufacturers**.

Control

To adapt to any fluid circuit configurations

For the automotive industry, precise testing is an integral part of striving for maximum vehicle reliability. Thus, for full and rigorous control of vehicle equipment, many types of test benches are used, with numerous functions and the ability to handle various fluids.

■ TEST BENCHES

Fluid supply networks, in particular compressed air and vacuum, must easily adapt to individual test bench configurations, thus providing optimum efficiency.



THE LEGRIS ANSWER

Transair networks for compressed air, vacuum, inert gases and cooling water.

- Perfectly suited to test bench environments.
- Assembly of connections under pressure allows maintenance without production line shut down.
- Cost saving, thanks to easy, instant assembly and high flow performance.
- TÜV certified.



Components adapted to the requirements of **test bench usage.**

■ ENGINE TEST BENCHES

In order to test working engines, these benches require circuits for oil and cooling water.

At the end of the mechanical assembly line, vehicle engines are systematically tested. Compressed air circuits are widely used, which must withstand **large variations** in operating conditions and be capable of enabling continuous use.



THE LEGRIS ANSWER

DIN 2353 / ISO 8434-1 couplings fitted with **DiNova** rings, for hydraulic circuits.

- Long lasting performance, ensured by 3 bites and 2 seals.
- Withstand aggressive fluids and high temperatures, thanks to the seal material (PTFE).
- Safe connection even under vibration.



Components suitable for the requirements of **test bench operators and manufacturers.**

THE LEGRIS ANSWER

push-in fittings in HR polymer, chemical nickel-plated brass and stainless steel, complete with a range of **pneumatic function fittings.**

- Extensive range, in terms of possible configurations, compatibility with fluids and functionality.
- Easy and quick operation.
- Optimum performance with nylon, polyurethane and FEP tubing.



Components suited to the requirements of **test bench users and manufacturers.**

A dedicated range of services

To support our customers and reinforce their productivity

Legris offers a comprehensive range of services to support its customers within the automotive industry - especially helping them to reinforce safety and to improve both productivity and energy efficiency.

■ SAVING ON DESIGN TIME

Legris offers the facility –via legris.com or on a CD ROM- to download **CAD drawings** for a large number of products. Each drawing can be directly integrated into an assembly, with the associated nomenclature. In addition, for Transair networks, **dedicated software** is available to quickly size a pipework system or network, complete with nomenclature. These services enable time saving in equipment sizing and design, ensuring that the selected parts are suitable for use with other components within an assembly.



■ OPTIONS FOR ORDER PLACEMENT

Depending on their structure or organisation, Legris customers can choose their preferred means of placing an order: **EDI transmission**, via **legris.com**, the Legris e-commerce website, or by optical reading of bar codes and automatic transfer over the telephone network (**online** order placement system). Each customer can choose the most economical, the quickest or the easiest method to use.



■ OPTIMIZED SUPPLIES

Legris electronic catalogues are specifically designed for customers who purchase via the Internet (**e-procurement**). "Tailor-made" data bases, these **e-catalogues** show all product details: product codes and descriptions, dimensions, high resolution pictures, CAD drawings...etc. The result: **lower** purchasing and administrative **costs**, **rationalisation** of internal processes and reliable supplier information.



An offer available worldwide

To support our customers all over the world

The international development of the automotive industry results in an industrial presence in numerous countries throughout the world. With 25 sales subsidiaries, 10 industrial and logistic locations and a network of agents and distributors, Legris ensures its availability and provides the technical back-up to support customer development.



HEAD QUARTERS

Legris SA
BP 70411 - 74 rue de Paris
35704 RENNES cedex 7
Tel. +33 2 99 25 55 00
Fax +33 2 99 25 55 99
webcontact@legris.com

ARGENTINA (Connectic)

**Automacion
Micromecanica SAIC**
Mariano Moreno 6548
1875 Wilde - BUENOS AIRES
Tel. 54 11 4206 6285
Fax 54 11 4206 6281
micro@micro.com.ar

AUSTRALIA

**Legris Australasia
Pty Ltd**
Unit 10 - 8 Mc Lachlan Avenue
ARTARMON NSW 2064
Tel. +61 2 9436 4300
Fax +61 2 9439 6511
legris.australia@legris.com

AUSTRIA

Legris GesmbH
Aredstrasse 29
2544 Leobersdorf
Tel. +43 (0) 2256/65331
Fax +43 (0) 2256/65332
legris.cee@legris.com

BELGIUM

LUXEMBOURG

Legris Belgium SA
454 Chaussée d'Alsemberg
1653 Dworp
Tel. +32 2 333 09 99
Fax +32 2 332 11 27
legris.be@legris.com

BRAZIL

Legris do Brasil Ltda
Av. Imperador Pedro II, n. 1.201
09770-420 - S.B.C. SAO PAULO
Tel. +55 11 4332 9200
Fax +55 11 4332 5579
legrisbrasil@legris.com.br

CHILE (Connectic)

Microtec SA
Parinacota 270
Quilicura
Tel. +56 02 443 6241
Fax +56 02 443 6083
micro@entelchile.net

CHINA

**Legris Fluid
Control System Co. Ltd**
NO 50 Chunhui Zhong Road,
XiShan Economic Development zone
WUXI 214101, JiangsuProv.
Tel. +86 510 826 5656
Fax +86 510 826 6922
sales@legris-china.com

CZECH REPUBLIC

Legris SRO
Brnenska 668
664 42 MODRICE
Tel. +420 5 4721 6304
Fax +420 5 4721 6301
legris.sro@legris.com

DENMARK

Legris Danmark A/S
Kohavevej 3B
2950 Vedbaek
Tel. +45 98 204 111
Fax +45 98 204 311
legris.denmark@legris.com

EGYPT

**Egyptian Kuwaiti
Engineer Office**
3, Elemam Hassan Maamoun
6th zone
NASR CITY
Tel. +20 202-2740550
Fax +20 202-2740955
gskekeo1@yahoo1.com

FRANCE

Legris Division France
BP 70411 - 74 rue de Paris
35704 RENNES cedex 7
Tel. +33 2 99 25 55 00
Fax +33 2 99 25 55 98
divfrance@legris.com

GERMANY

Legris GmbH
Kurfürststr. 15
64546 MORFELDEN-WALLDORF
Tel. +49 6105 91 09-0
Fax +49 6105 91 09 25
info-GmbH@legris.com

GREECE

MAG SA
Spirou Patsi 121
Votanicos - 11855 ATHENES
Tel. +30 210 341 2094
Fax +30 210 341 2095
maghellas@tee.gr

HOLLAND

Legris BV
Postbus 74 - 1380 AB WEESP
Pampuslaan 112 - 1382 JR WEESP
Tel. +31 294 480 209
Fax +31 294 480 294
legris.bv@legris.com

HUNGARY

Legris Hungary
Gyortfy István u. 1/b
1089 BUDAPEST
Tel. +36 13030568
Fax +36 13030568
legris.hungary@legris.com

ICELAND

Landvelar
Smidjuvegur 66
PO Box 20 - 202 KOPAVOGUR
Tel. +354 557 6600
Fax +354 557 8500
landvelar@landvelar.is

INDIA

Legris India Pvt. Ltd
99 Pace City-1, Sector 37
GURGAON 122 001
Tel. +91 124 503 4227
Fax +91 124 503 1113
legris.india@legris.com

ISRAEL

Ilan & Gavish Automation Ltd
26 Shenkar St. Qiryat-arie 49513
PO Box 10118
Petach Tikva 49001
Tel. +972 3 922 1824
Fax +972 3 924 0761
iandg@internet-zahav.net

ITALY

Legris SpA
Via Idiomi N.3/6
20090 ASSAGO (MI)
Tel. +39 02 4886 13.11
Fax +39 02 4886 1313
legris.italia@legris.com

IVORY COAST

Poly Service Technique
15 BP 450
450 ABIDJAN
Tel. +225 24 75 17
Fax +225 24 79 28
pst.ci@aviso.ci

JAPAN

Legris K.K.
Konno Building
7-10-6 Akasaka - Minato-Ku
107 TOKYO
Tel. +81 3 3585 03 17
Fax +81 3 3582 09 40
legris.japan@legris.co.jp

**KOREA****Korea Pneumatic System**

153-030 RM 206
Saehan Venture World B/D
113-15 Shiheung-dong
Keumchun-gu
SEOUL
Tel. +82 2 2617 5008
Fax +82 2 2617 5009
import@vtec.dk

MOROCCO**A F I T**

5 rue Emir Abdelkader
20300 CASABLANCA
Tel. +212 22 618 375
Fax +212 22 618 351
afit.casa@techno.net.ma

POLAND**Legris Polska**

ul. Lubinowa 4^a
Budynek M2
03-878 Warszawa
Tel. +22 744 22 20
Fax +22 678 91 91
legris.polska@legris.com

PORTUGAL**Legris, Lda.**

Rua Dr. Carlos da Silva Mouta
238 Loja B
4475-620 SANTA MARIA AVIOSO
Tel. +351 22 982 1922
Fax +351 22 982 1924
legris.lda@legris.com

RUSSIA**Legris Industries OOO**

20/2 Bersenevskaya nab,
Bur. 304 et 305
119072 Moscou
Tel. +7 495 959 3019
Fax +7 495 959 0948
legris.russia@legris.com

SCANDINAVIA**Legris Scandinavia AB**

Box 33
S-230 53 ALNARP
Tel. +46 40 415700
Fax +46 40 532100
legris.scandinavia@legris.com

SINGAPORE**Legris SE Asia Pte Ltd**

8, Jalan Kilang Timor 01-04
Kawalram House
SINGAPOUR 159305
Tel. +65 6271 6088
Fax +65 6274 9978
legrisea@legris.com

SOUTH AFRICA**Legris South Africa (Pty Ltd)**

PO Box 38621
BOOYSENS 2016
Johannesburgh (ZA)
Tel. +27 11 683 8335
Fax +27 11 683 1080
legcon@cybertrade.co.za

SPAIN**Legris Cenrasa**

Pol. Ind. La Ferreria
c/de l'Alimentació, 2-4
08110 MONTCADA I REIXAC
(Barcelona)
Tel. +34 93 575 06 06
Fax +34 93 575 38 07
legris.cenrasa@legris.com

SWITZERLAND**Legris AG**

9 rue J. Renfer
2504 BIEL/BIENNE
Tel. +41 32 344 1080
Fax +41 32 344 1070
legris.ch@legris.com

TAIWAN**Legris Taiwan Co Ltd**

1 & 2F, No 240 Gao Gung Road
Taichung, Taiwan (R.O.C)
Tel. +886 4 2263 9539
Fax +886 4 2263 5913
legris@legris.com.tw

TUNISIA**Automatisme et Régulation Industrielle**

Rue El Khwarezmi Z.I. Saint-Gobain
2014 Megrine Riadh
Tel. +216 71 427 067
Fax +216 71 428 277
ari@gnet.tn

TURKEY**MERT**

Tersane Caddesi 43
Karakoy - ISTANBUL
Tel. +90 212 252 84 35
Fax +90 212 245 63 69
info@mert.com

UNITED KINGDOM**Legris Limited**

Gloucester Business Park
Hucclecote
GL3 4AB GLOUCESTER
Tel. +44 1452 623 500
Fax +44 1452 623 501
salesuk@legris.com

UNITED STATES**Legris Incorporated**

7205 E. Hampton Avenue
MESA - AZ 85209
Tel. +1 480 830 0216
Fax +1 800 839 7556
marketing@legris-usa.com

Legris designs, produces and sells technical components designed for numerous industrial fields.

The Legris offer, innovative and high quality, is specifically adapted to various activities, including:



AUTOMOTIVE PROCESS



FOOD



PACKAGING



Present in 76 countries, Legris specialist teams listen to your requirements and respond with the best advice and solutions.

Do not hesitate to contact us and discover how, by working closely together, we can improve your productivity.

www.legris.com
www.transair.legris.com